



VISONIX
The Vision of the Future

Combi 200

Refraction unit

Combi 200 & 200 H

Comfortable refraction units with two-instruments

Combi 200 refraction unit right

REF 8105-0201-01

Combi 200 refraction unit left

REF 8105-0202-01

Combi 200 H unit refraction right (height adjustment)

REF 7220059

Combi 200 H unit refraction left (height adjustment)

REF 7220060

Combi 200 offers a comfortable configuration as well as flexible expandability. Combi 200 includes a swivel sliding instrument table for two instruments and possesses a drawer element offering room for a trial lens set and other accessories. The hinged drawer feature offers the best working position during refraction everytime. The easily accessible control panel allows for simple and fast operation of Combi 200.

All units in the Combi series are equipped with an electrically operated patient's chair. The Combi 200 offers a chair that features variable back-rest, and a sliding seat position. The surface is covered with low maintenance leatherette. A flip-up footrest and swivel armrests round out the features of the Combi 200.

All Combi units can be extended with an integrated desktop drawer package offering more workspace to the operator. With this option both a PC and a lensmeter can be easily integrated in the working process of the refraction unit.

Unit features

- > Table height adjustment for Combi H
- > Rotatable drawer element with easily accessible control panel and handy storage tray
- > Beneficial drawer to support notched frame
- > Extendable desk top option

Comfortable refraction chair

- > Forward/Backward sliding seat (optional)
- > Swivel arm rest on both sides.
- > Variable backrest.
- > Footrest.

Technical specifications

Min. seat high	20.8 inches
Max. seat high	28.3 inches
Inclination	70° adjustable tilt
Seat adjustment 6.2 inches,	Back & forward
Arm rest	Can be swivelled to the side
Standards MDD, CE	MDD, CE

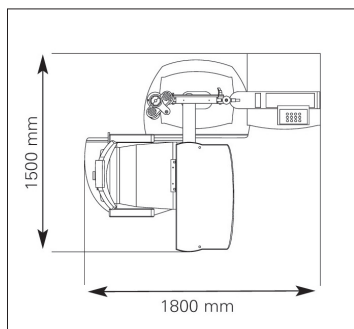

Swivel refraction chair



Variable arm rest

Visionix

5251 Shiloh Rd., Cumming, GA 30040 _Tel. (800) 292-7468

A company of Luneau Technology